



KINETICS SD 100

Slurry Dispense System

- Simple—simple flow path enables consistent process performance
- Precise—configurable slurry management resources
- Reliable—proven components and redundant operation

SYSTEM OVERVIEW

The Kinetics SD 100 Slurry Dispense System is a reliable and configurable dispense system for critical slurry and CMP process applications. The system accommodates single or dual source containers, and dispenses pre-mixed slurry either to the CMP polisher tools, or to an optional day tank. The day tank accommodates contents of multiple supply drums, to ensure availability of slurry dispensed to the fab. Slurry is dispensed to the fab points-of-use using either diaphragm or magnetically levitated centrifugal pumps. Source and dispense loop circulation is used to prevent settling of slurry material. Optional transfer and dispense filters are available, to remove large slurry agglomerates. An optional automated filter flush-purge module is available to ensure seamless delivery of slurry material. The system is designed to minimize dead-legs, and uses high-performance components proven to work in tough slurry environments. User-defined flushing sequences keeps the system clean, and maintains the slurry for optimum process performance.

KEY FEATURES:

- Single or dual slurry source containers, typically 200 liter drums
- 5 to 20 liter per minute dispense rate
- Reliable diaphragm pump operation
- Redundant pumping modules for uncompromised reliability
- Transfer and fab loop circulation, to prevent slurry settling.
- Humidified N₂ for blanketing of source containers and day tank
- Polyethylene and polypropylene materials-of-construction
- Polypropylene cabinet

OPTIONS:

- Stirrer devices for source drums and day tank
- Magnetically-levitated centrifugal pump for slurry dispense
- Single transfer filter
- Single or dual-stage dispense filtration, with redundant filter paths
- Automated DI water and N₂ services for dispense filters
- User-defined flushing/purging sequences
- Day tank - 200, 500 or 1000 L
- Automated back-pressure control for distribution loop
- Source drum cabinet (single or dual)
- Day tank cabinet, up to 500 L
- Internal slurry sample valve
- Bar code reader

PROCESS FLOW DIAGRAM

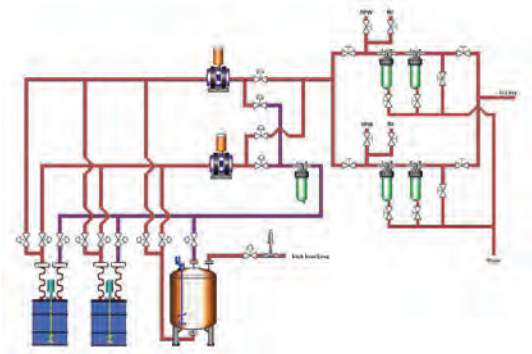

Configuration showing two source drums, day tank, transfer and dispense filters, and drum/tank stirrers

RELIABILITY

- MTBF > 4500 Hours¹
- MTBA > 2500 Hours¹
- MTTR < 2 Hours
- Availability > 99.9%

¹Filter change-out not considered part of system down-time or repair time.

TECHNICAL DATA

CONTROLS

- Allen-Bradley SLC 500 or Siemens S7 series PLC
- Allen-Bradley Panelview 550 or Siemens TP177B HMI, displaying:
 - System P&ID status
 - Alarm and warning screens
 - Distribution valve box status
 - Pump and filter runtime screens
 - Password-protected maintenance screens
 - Manual activation of valves and pumps
- Connectivity to factory control system

SAFETY FEATURES

- Segregated pumping compartments for online maintenance
- Local and remote EMO
- Cabinet leak detection and door interlocks
- Audible and visual warnings and alarms
- Options for exhaust and high-flow sensors

SPECIFICATIONS

PARAMETER	CAPABILITY
Application	Oxide, tungsten, polysilicon, STI or copper slurry applications
Dispense Flow Rate	5 LPM, 20 LPM optional, at 40 psi ¹ (3 barg)
Flow Path Size	½-inch standard (¾-inch optional)
Loop Pressure Specification ²	+ 2 psi across all process tools
Day Tank Sizes	Optional, 200, 500 and 1000 Liters
Cabinet Materials	Polypropylene
Transfer Filter Housing	Optional, single 10"
Dispense Filter Housings	Optional: <ul style="list-style-type: none"> • 2, 10" (in parallel) • 2, 20" (in parallel) • 2, dual-series trains (in parallel)
Source Containers	• Single or Dual Drums (200L)
Cabinet Footprint, dispense module (WxDxH)	69" x 40" x 75" (1730mm x 1000mm x 1900mm)
Footprint, filtration module (WxDxH)	37" x 40" x 75" (930mm x 1000mm x 1900mm)
Component Materials—Standard	<ul style="list-style-type: none"> • Polyethylene or PFA valves • PE pumps and pulse dampeners (PTFE diaphragms) • PFA tubing and fittings • Polyethylene filter housings • HDPE or PE day tanks

¹Dispense flow rate and pressure measured at outlet of slurry dispense unit.

²Loop pressure guarantee only available with optional magnetically levitated centrifugal pumps.

FACILITY REQUIREMENTS

UTILITY	REQUIREMENT	CONNECTION TYPE
DI Water	Normal 2 GPM @ 55 psi, Peak 5 GPM @ 55 psi (Peak 20 LPM @ 4 barg)	½" PFA Flare
N ₂	2 SCFM @ 90 psi (3.5 Nm ³ /hr @ 6 barg)	½" SS Swagelok
CDA	18 SCFM @ 90 psi (31 Nm ³ /hr @ 6 barg)	3/8" SS Swagelok
Exhaust, dispense module	128 SCFM @ 2" H ₂ O (217 Nm ³ /hr @ 2" H ₂ O)	6" Pipe Flange
Exhaust, filtration module	118 SCFM @ 2" H ₂ O (200 Nm ³ /hr @ 2" H ₂ O)	6" Pipe Flange
Process Drain	7 GPM @ 70 psi (25 LPM @ 5 barg)	1" FNPT, polypropylene
Cabinet Drain	Gravity	1" FNPT or DN15 butt weld, polypropylene
Power—with centrifugal pumps	100 to 240 VAC, 50–60 Hertz, 15 amps	¾" Conduit
Power—with 2 magnetically levitated pumps	3 phase 200 or 208 V, 10 amps Or 1 phase 230V, 16 amps	¾" Conduit